

ONE COMPANY, ONE TEAM.
ONE EXPERTISE, ONE EARTH.

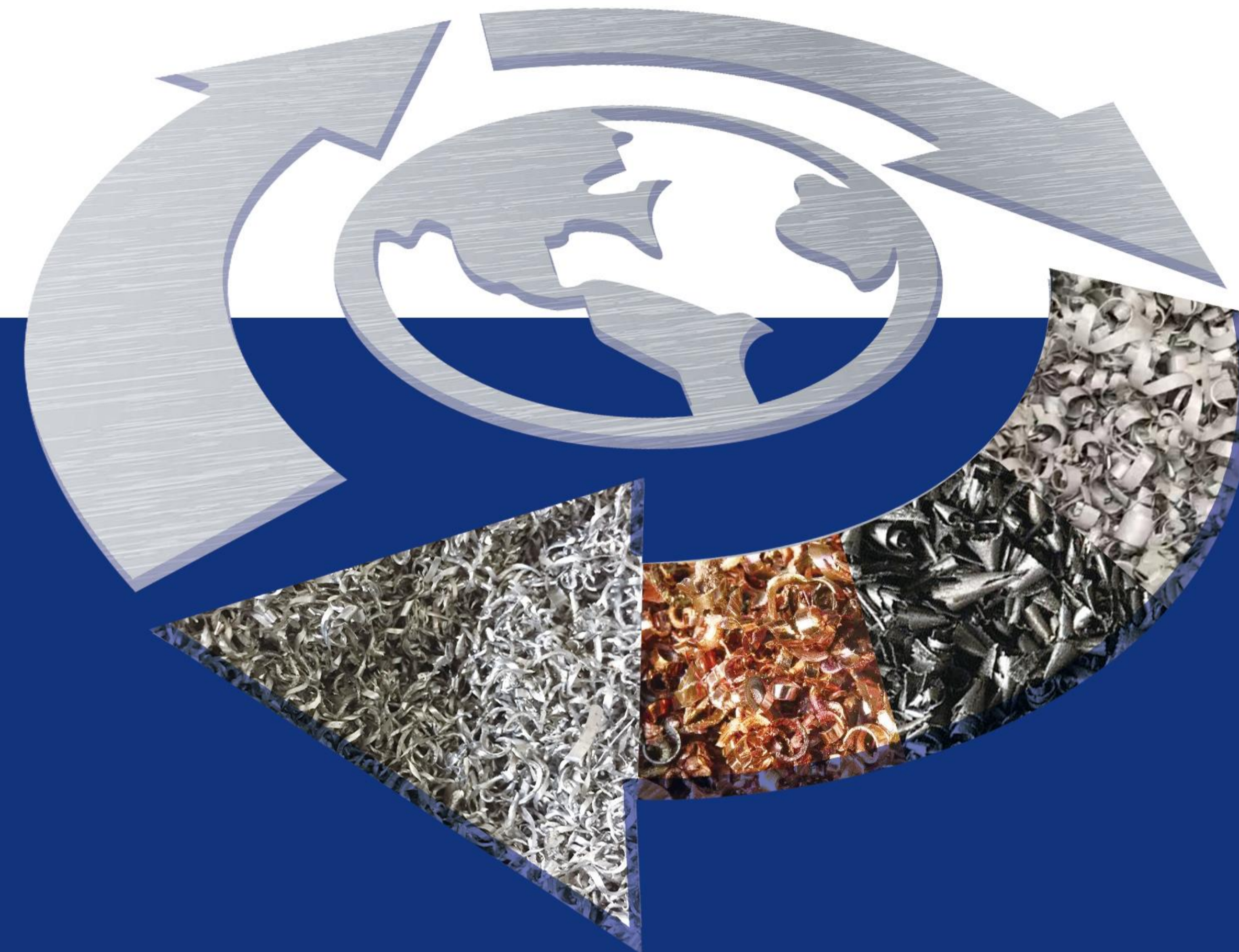

JIANGYIN TITAN MACHINERY EQUIPMENT CO., LTD
Phone: +86 13921207767
aaron@titan-recycling.com
<https://titan-recycling.com/>





Q43 series alligator type metal shear

Technical Specification

Features

Superior Hydraulic Performance: Compact and quiet hydraulic system ensures smooth operation with overload protection. Features a large cutting surface and easy blade adjustment.

Flexible Control: Manual and automatic modes enable operation start/stop at any position with adjustable cutting size for optimal efficiency.

Energy-Efficient Design: Optimized parameters minimize energy consumption, ideal for furnace charge preparation in metal recycling and mini-mills.

Wide Model Range: 9 shear force levels (60–500 tons) and blade lengths from 400mm to 1600mm to meet diverse requirements.

Rapid Cutting Mode: Special rapid models automatically switch speeds for larger materials without extra power, doubling efficiency while maintaining full force.

Overview

TITAN Q series scrap metal shear processes structural steel and metal parts for recyclers and smelters. It delivers furnace-ready charging material efficiently and without heat.

Benefits

Value-added Processing: Converts scrap metal into furnace-ready charge for direct value enhancement.

Improved Smelting Efficiency: Reduced surface area enables faster melting and lower energy consumption.

Lower Storage & Transport Costs: Decreased material volume cuts storage space and freight expenses.

Materials

Metal Structures: steel structures, profiles, reinforcement bars, vehicle frames.

Vehicle Components: waste tires, rims, bicycles.

Other Metal Solid Waste.

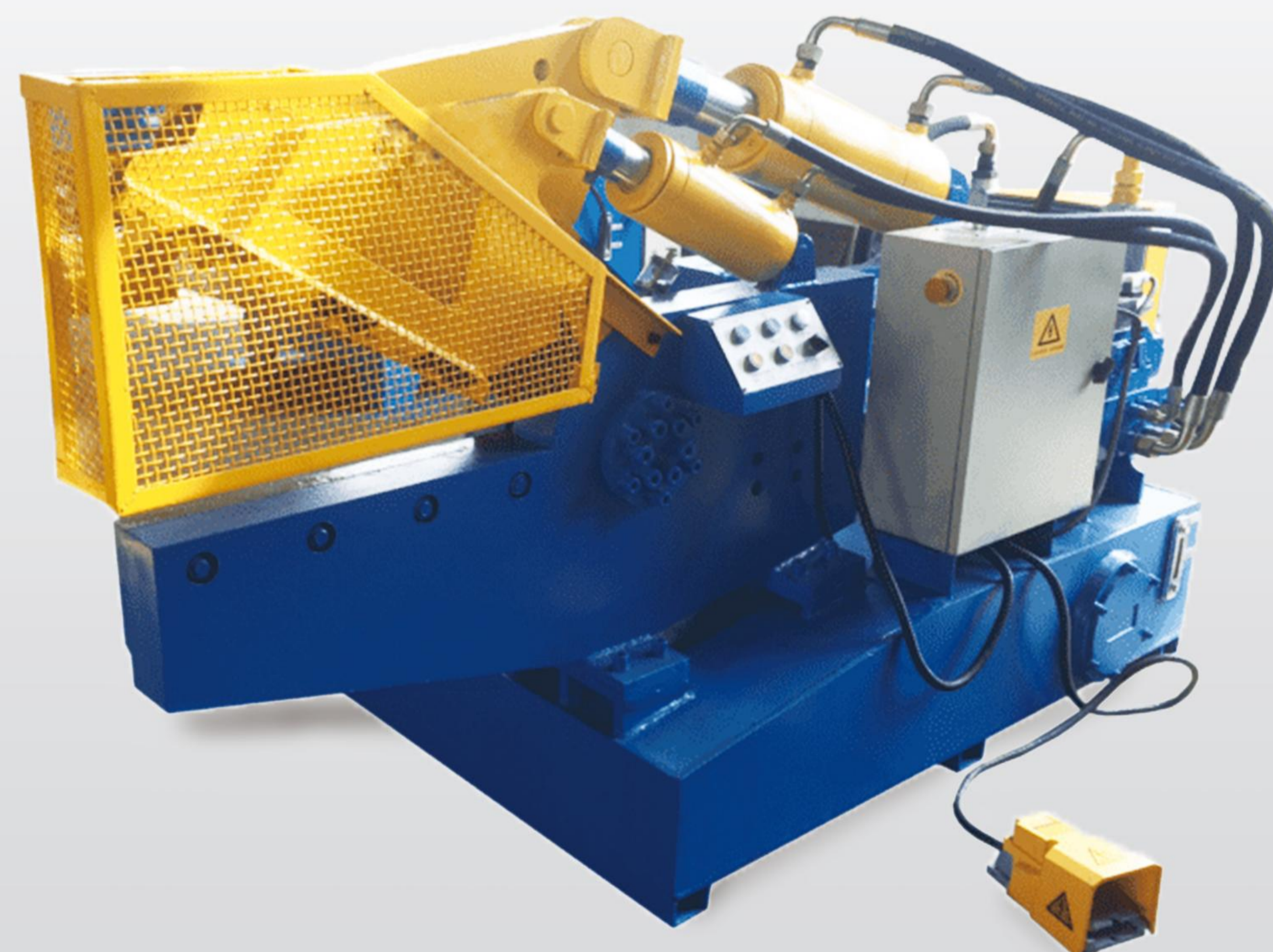
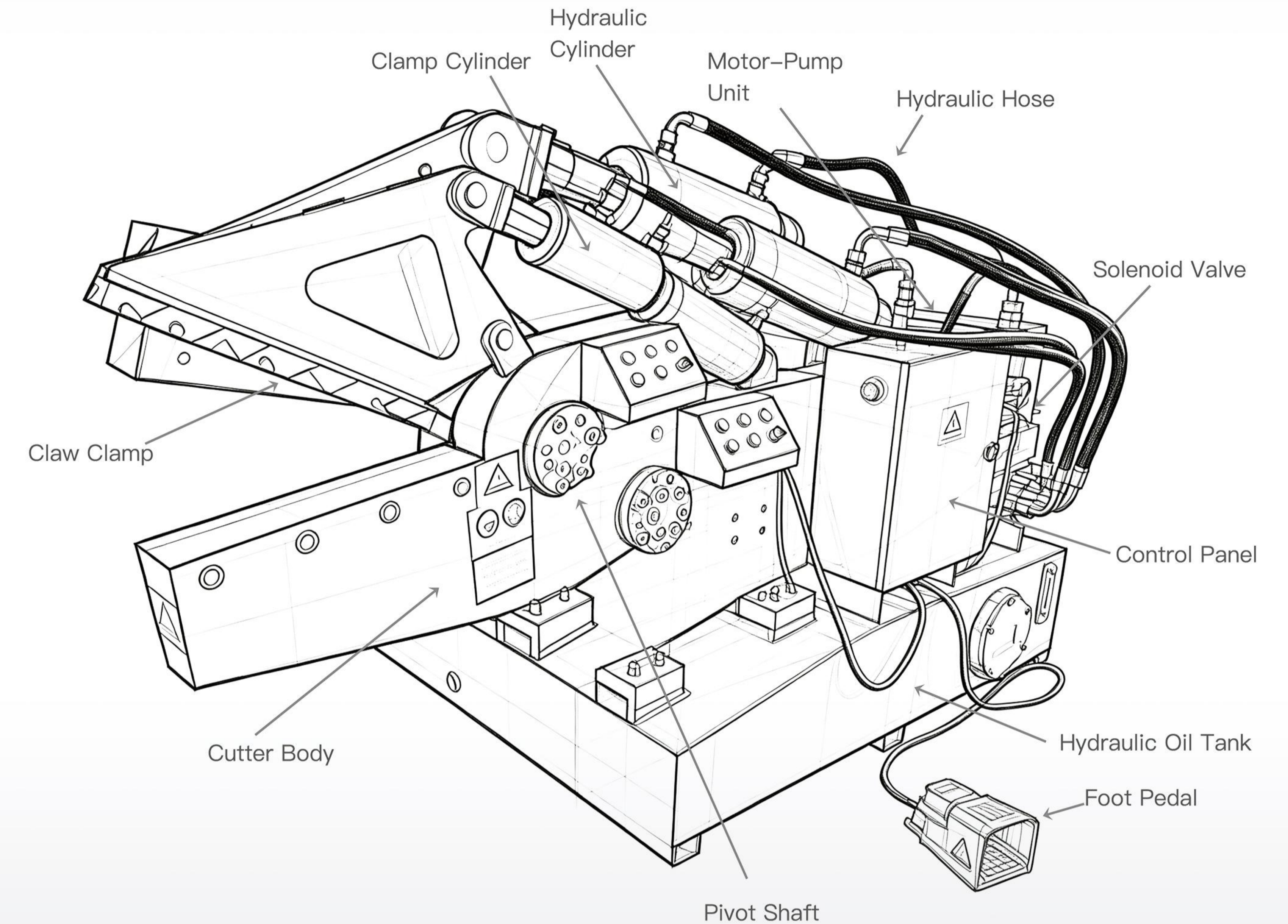

Model	Maximum Shear Force	Blade Length (mm)	Max. Blade Opening (mm)	Motor Power (kW)
Q43-1200	1200 KN (120 T)	800	340	15
Q43-1600	1600 KN (160 T)	800	380	18.5
Q43-2000	2000 KN (200 T)	1000	460	22
Q43-2500	2500 KN (250 T)	1200	530	15 x 2
Q43-3150	3150 KN (315T)	1200	530	18.5 x 2
Q43-4000	4000 KN (400T)	1500	670	22x 2
Q43-5000	5000 KN (500T)	1600	700	22x2

This product series is customizable for specific materials and conditions. The integrated Q43E model features a compact, space-saving design for in-line operation.